



DOMINANT

M U L T I P A C K

Packaging Machine Manufacturer and service provider



PEARL- 2S SERVO

PACKAGING SOLUTION FOR
SEEDS | SNACKS | GRAINS
POWDER | FRYUMS |



Pillow Pouch



Gusset Pouch

TECHNICAL SPECIFICATIONS

Model No	PEARL-2S
Max. Speed	Upto 80 bpm
Filling Capacity	25 gm to 1000 gm
Min.Roll Size	120 mm
Max.Roll Size	520 mm
Supply Voltage	415 VAC, 3-ph
Power	4 kw
Air Consumption	7 CFM

DOMINANT MULTIPACK

966/1, Nr. Conmet Cross road, G.I.D.C Makarpura, Vadodara 390010, Gujarat, India
Phone: +91 9106379904 E-mail : info@dominantmultipack.com

❖ SALIENT FEATURES

- | | |
|--|--|
| ▪ Controlled by most advanced PLC from Mitsubishi - with touch screen operating panel. | ▪ Integrated PID temperature controllers in PLC, precisely controls temperature within limits. |
| ▪ Servo operated horizontal sealing for fast and better sealing. | ▪ Servo operated bag pulling for fast and accurate bag pulling. |
| ▪ Easy Forming assembly changeover. | ▪ Recipe functions for easy job changeover. |
| ▪ Air Shaft for easy Roll changeover. | ▪ Motorized Web tracking System. |
| ▪ Enough Safety devices used in control panel to protect. | ▪ 3 speed VFD controlled motorized Roll unwinding controlled by 4 sensors. |
| ▪ Sturdy and versatile construction of machine. | ▪ Perforation attachment to offer chain of pouches. |

❖ FILLER OPTION



Multihead Weigh Filler

| Snacks | Seeds | Grains
| Chips | Fryums | Tea | Poha



Auger Filler

| Spice Powder | Flours
| Milk Powder | Pesticides



Volumetric Cup Filler

| Free Flow Powder
| Sugar | Detergent

❖ Machine Layout

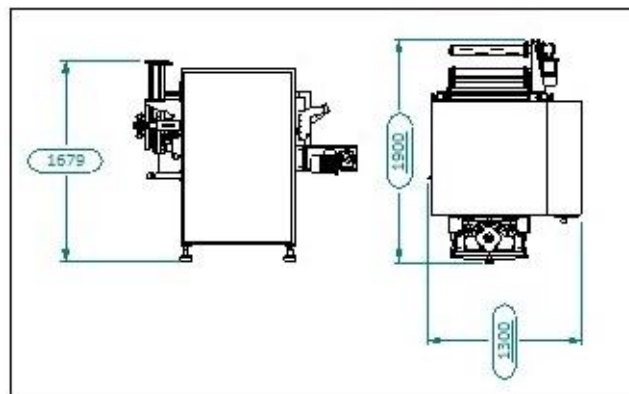

DOMINANT MULTIPACK

966/1, Nr. Conmet Cross road, G.I.D.C Makarpura, Vadodara 390010, Gujarat, India
Phone: +91 9106379904 E-mail : info@dominantmultipack.com