



DOMINANT

M U L T I P A C K

Packaging Machine Manufacturer and service provider



PEARL- 100 PNEUMATIC

**PACKAGING SOLUTION FOR
SEEDS | SNACKS | GRAINS
POWDER | FRYUMS |**



Pillow Pouch



Gusset Pouch

TECHNICAL SPECIFICATIONS

Model No	PEARL-100
Max. Speed	Upto 60 bpm
Filling Capacity	10 gm to 1000 gm
Min.Roll Size	120 mm
Max.Roll Size	520 mm
Supply Voltage	415 VAC, 3-ph
Power	3 kw
Air Consumption	7 CFM

DOMINANT MULTIPACK

966/1, Nr. Conmet Cross road, G.I.D.C Makarpura, Vadodara 390010, Gujarat, India
Phone: +91 9106379904 E-mail : info@dominantmultipack.com

❖ SALIENT FEATURES

- | | |
|---|---|
| <ul style="list-style-type: none"> Controlled by most advanced PLC from Mitsubishi with touch screen operating panel. Recipe functions for easy job changeover. | <ul style="list-style-type: none"> Integrated PID temperature controllers in PLC, precisely controls temperature within limits. Easy Forming assembly changeover. |
| <ul style="list-style-type: none"> Motorized Roll unwinding controlled with 4 sensors. Perforation attachment to offer chain of pouches. | <ul style="list-style-type: none"> Air Shaft for easy Roll Mounting Sturdy and versatile construction of machine. |
| <ul style="list-style-type: none"> Enough Safety devices used in control panel to protect. | <ul style="list-style-type: none"> Motorized Web tracking System. |

❖ FILLER OPTION



Multihead Weigh Filler

| Snacks | Seeds | Grains
| Chips | Fryums | Tea | Poha



Auger Filler

| Spice Powder | Flours
| Milk Powder | Pesticides



Volumetric Cup Filler

| Free Flow Powder
| Sugar | Detergent

❖ Machine Layout

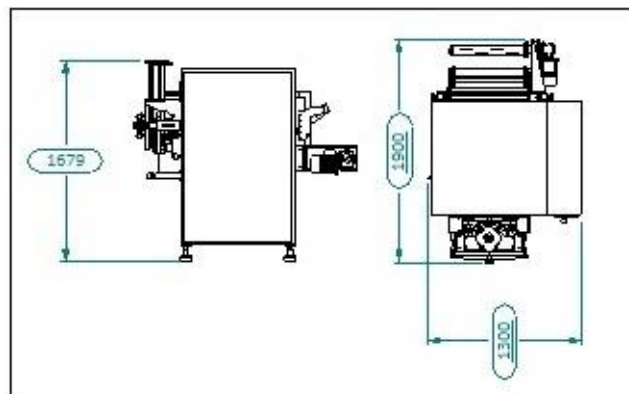

DOMINANT MULTIPACK

966/1, Nr. Conmet Cross road, G.I.D.C Makarpura, Vadodara 390010, Gujarat, India
Phone: +91 9106379904 E-mail : info@dominantmultipack.com